

PANEL CUT-OUT

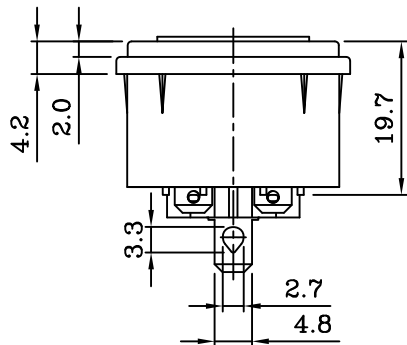

**SPECIFICATION (SWITCH) :**

- 1.CIRCUIT : DPST ON-OFF.
- 2.CONTACT RESISTANCE : 30MΩ Max.
- 3.INSULATION RESISTANCE : DC 500V 100MΩ Min.
- 4.WITHSTAND VOLTAGE : AC 1000V 1 Minute.
- 5.OPERATION FORCE : 800±300g.
- 6.ELECTRICAL LIFE : 10,000 Cycles At Full Load.
- 7.OPERATING TEMPERATURE RANGE : -25°C ~ +85°C.
- 8.SOLDERING : 280°C FOR 3 Sec.
- 9.DIELECTRIC STRENGTH: 2000V AC 1 Minute.
- 10.BODY MATERIAL : Black Glass-Fiber Thermoplastic. UL 94V-2~0.

**SPECIFICATION:**

1. INSULATION RESISTANCE: OVER 100MΩ 500V DC.
2. DIELECTRIC STRENGTH: 2000V AC ONE MINUTE.
3. Body Materil: Black Glass-Fiber Thermoplastic . UL 94V-2~0



Rating:AC 10A 250V	
Mark	Safety Regulation
Ⓢ	CCC
Rating:AC 15A 250V	
Mark	Safety Regulation
Ⓢ	CULUS

DRAWING:C:DG\NEW-R\T\301SN\R-301SN(79).DWG



富灣股份有限公司  
RICH BAY COMPANY LTD.  
台北縣樹林市東興街57號  
NO. 57, Tung Hsing St.,Shu-Lin Town,  
Taipei Hsien, Taiwan, R. O. C.  
TEL:886-2-86867781~4 FAX:886-2-86867780  
http://www.richbay.com.tw

DRAWN BY	UNIT	UNIT QTY	SCALE	TOLERANCE	PRODUCT NO.	R-301SN(79)	REV
	mm	1	1:1	X.XX±0.1 XX.XX±0.2 XXX.XX±0.3			
RD 100.02.22 張育誠	APPROVED BY		RD 100.03.23 戴銘璋	ID NO	110222A03	INTERIM NO.	A
				DESCRIPTION		NEW NO.	